

Solid State Pressure Sensor

ANALOG
OUTPUT

STX Series – Model 13A Low Pressure

FEATURES

- Dual-in-line Package
- Calibrated Span and Offset
- Rigid Nylon Package
- 0.15 PSI to 3.0 PSI
- Flow meters, breathing equipment

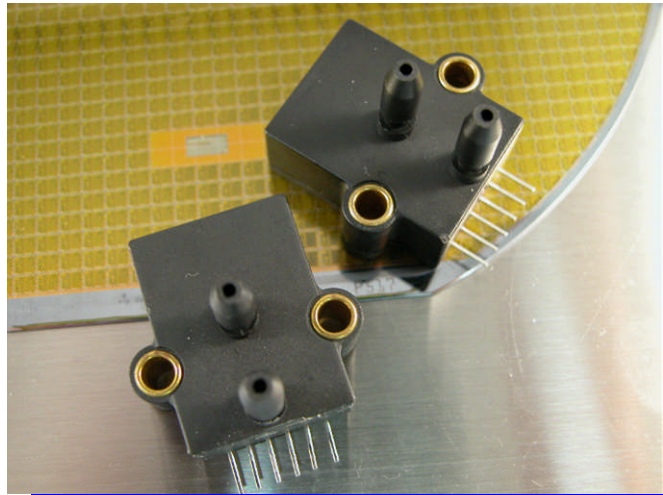

DESCRIPTION

The STX 13A Series is a smart pressure sensor with a calibrated and amplified analog output. Compensation of sensor offset, sensitivity, temperature drift and nonlinearity is accomplished in the factory via the latest ASIC technology with calibration coefficients stored in an on-chip EEPROM.

A variety of output configurations, including response time and voltage levels are available to provide a simple and ready-to-use solution for a wide range of applications. The low voltage version operates from 2.7 to 3.3V while the regular version operates from 4.5 to 5.5V.

The STX 13A Series, are specifically intended for **low to very low pressures**. The lowest pressure ranges available are **0.5 inH₂O** and **1 mbar**. Custom ranges and calibrations are available. Please contact the factory for details.

SENSORMATE

10, Industries E. Rd. III, Lukang,
Chang Hua, Taiwan 50544
Tel: +8864 7811839 Fax: +8864 7811837
www.sensormateonline.com

Sensormate Enterprise Co., Ltd. reserves the right to change specifications without prior notice

Characteristics

Unless otherwise specified, all parameters are measured at 25 °C, 60% RH and 5Vdc excitation

Parameters	Min	Typ	Max	Unit
Supply Voltage ^{Note 1}	2.7 to 3.3		4.5 to 5.5	V
Supply Current			2.5	mA
Zero Output	0.412	0.500	0.588	V
Span Output		4.00		V
Linearity		±0.5		% FS
Accuracy ^{Note 2,6}			2.2	% FS
Response Time		1	2	ms
Thermal Hysteresis		±0.2		% FS
Over Pressure ^{Note 5}			3X or 2.5 psi	Rated Pressure
Temp - Compensated	0		+50	°C
Temp - Operating	-20		+85	°C
Temp - Storage	-40		+125	°C

Notes:

1. Specify desired operating voltage range when ordering. Output is ratiometric to supply voltage
2. Accuracy includes non-linearity, hysteresis, TCS and TCO inside the compensated temperature range, best fit straight line definition
3. Wetted material Port A: Ceramic, Au, glass, silicon, RTV, Nickel and Epoxy
4. Wetted material Port B: Ceramic, silicon, glass and RTV
5. Whichever is higher
6. Accuracy for 0.15 psi range is 2.7%FS

Dimensions

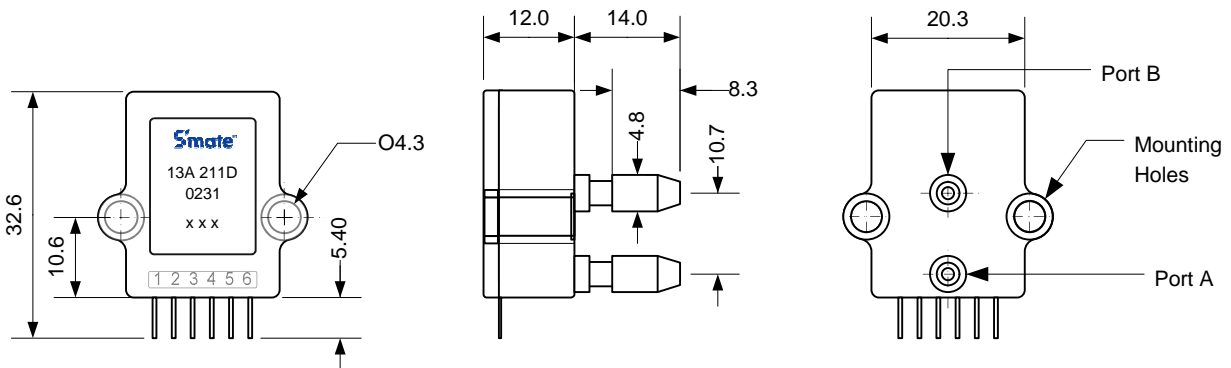

Notes:

- Solder reflow max.. 250 °C 5s
- All dimensions in mm
- Port B is used for positive gage and differential

Ordering Information

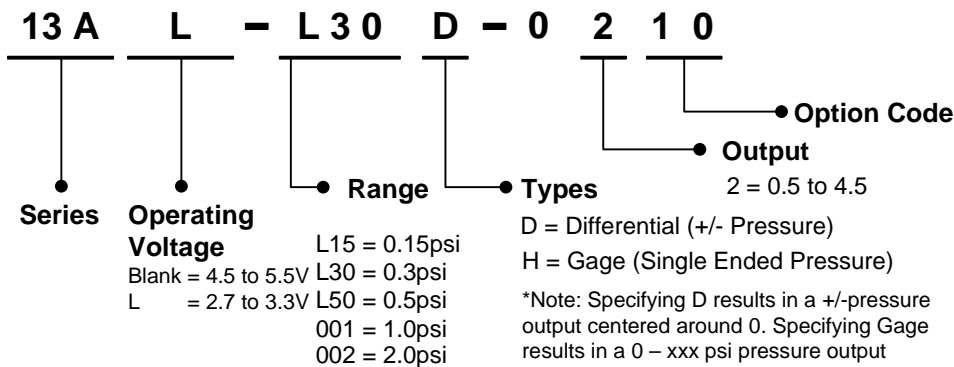

Pin #	Description
1	SUP
2	N.C.
3	N.C.
4	N.C.
5	GND
6	OUT

NOTE: A 0.1uF capacitor must be connected between SUP and GND
N.C. pins must be left floating



10, Industries E. Rd. III, Lukang,
Chang Hua, Taiwan 50544
Tel: +8864 7811839 Fax: +8864 7811837
www.sensormateonline.com

Ver 1.5 4-Jan-10